

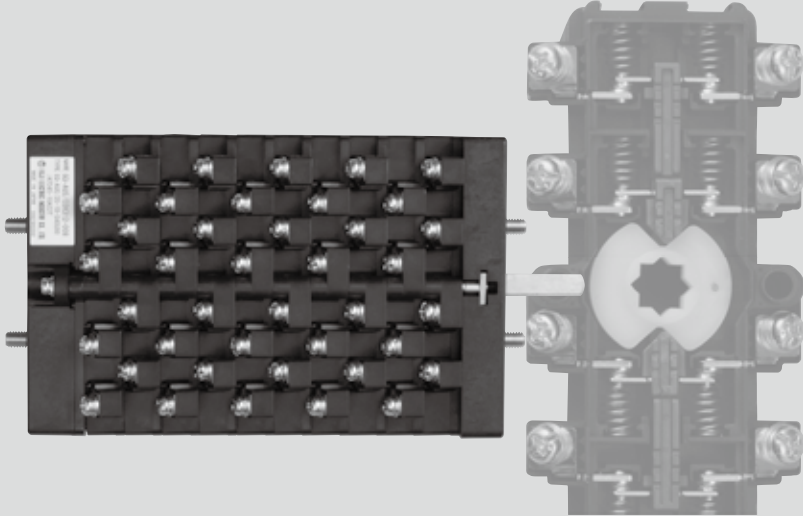

AUXILIARY SWITCH

GQ TYPE

1 unit 4 contacts
Multicontacts, Space - Saving type
Auxiliary Switch



FEATURES

Multicontacts, Space - Saving (Length)

1 unit has 4 contacts, which is twice more than existing models. Switch length can be substantially downsized.

Max. 15 units, 60 contacts

3 to 15 unit assembly is available for multicontact demand. In case of 15 unit, the number of contacts are 60.

Length comparison

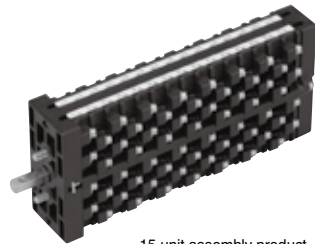
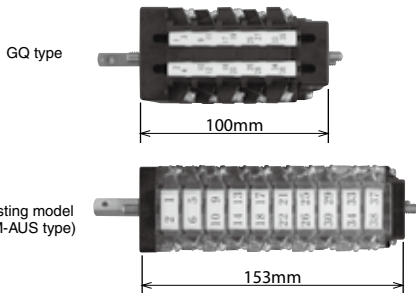

15 unit assembly product

High anti-flammability, oil resistance

To ensure high anti-flammability and oil resistance, PBT plastic is used for the body units.

GQ type PBT plastic (UL94-V0)

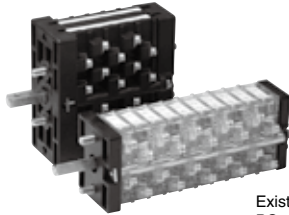

Existing model (BM-AUS type)
PC plastic (UL94-HB)

Wide variation of contact arrangement

Wide variation of contact arrangement is available by combination of more than 50 cams. A custom-made cam also available.

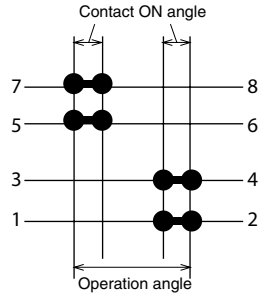

High reliability by grease-less

For the moving rod of the unit, a grease-less has been realized by adapting high slippery material. It's enhance high reliability over long-term use.

Rated insulation voltage 600V

Rated insulation voltage is enhanced to 600V from 250V of existing models.

SPECIFICATIONS (RATINGS, PERFORMANCE)

Standard : IEC60947-1, IEC60947-5-1

Specification		GQ
Rating	Rated insulation voltage (Ui)	600V
	Lighthing impulse (Uimp)	±6kV (1.2 / 50μs)
	Rated current-carrying capacity (Ith)	20A (silver contact)
	Max. wire size	5.5mm ²
	Screw size	M4×9
Performance	Withstand voltage	2,500V AC / 1min.
	Contact resistance	50mΩ or less (default)
	Mechanical life	50,000 times (switching frequency: 1,200 times / h, angular speed: 2π rad / s)
	Electrical life	50,000 times (AC-15, switching frequency: 360 times / h, angular speed: 2πrad / s) 20,000 times (AC-13, switching frequency: 360 times / h, angular speed: 2πrad / s)
	Shock resistance	500 m/s ²
	Vibration resistance	Frequency: 100Hz Amplitude: 0.05mm Time: 1 hour each 3 axial directions
Normal service condition	Operating temperature	-20 to 60°C
	Relative humidity	45 to 85%
	Altitude	2,000 m or less



AUXILIARY SWITCH

GQ TYPE

HOW TO ORDER

GQ-AUS / 2S - 10 - S40U00 / ST 090 - □ 20F20A
 ① ② ③ ④ ⑤ A B C D

No.	Item	Description	Note
①	Basic code	GQ-AUS type auxiliary switch	
②	Fix bolt	2 : M6 bolt 4 pcs (front and back) length: 10mm 6 : M6 bolt 4 pcs (front and back) length: 15mm	
③	Shaft shape	S : Standard shaft (□8mm)	※ "Shaft Shape"
④	No. of units	3 to 15 units	
⑤	Code and quantity of contact	S□: Silver single contact + Contact quantity U□: Gold single contact + Contact quantity	
A	Center position code	Ex.) ST : Operation at T position as center	※ "Operating Position"
B	Operation angle	Ex.) 090 : 90° operation	
C	Option specification code	No code : Contact ON angle = 15°	※ "Contact ON Angle"
D	Contact arrangement	Contact ON position	※ "Contact Arrangement"

OPERATING POSITION

Ex.) ST 090

Center position code
Operation angle

Front view
(Shaft sticking out side)

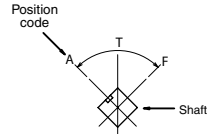
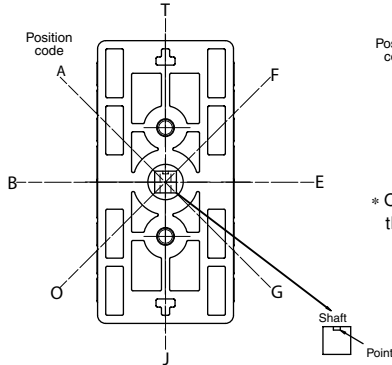

* Operating position is indicated by the shaft's point.

Ex.) Code : ST090 (90° operation at T position as center.)

In case, center position is between "A" and "T", the central position code shall be "AT".

SHAFT SHAPE

Code:S
(□8mm)

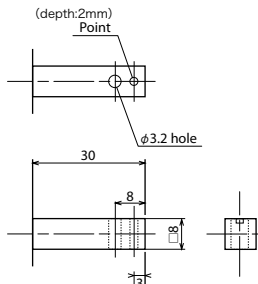

* We can design other length or head screw shaft different from standard shape.

CONTACT ARRANGEMENT

Ex.) 2 F 2 A

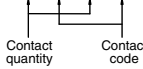

* Contact code means the position that shaft's point indicates when the contact is ON.
 *1 unit includes max. 4 contacts. (Contact quantity in 1 unit depends on contact arrangement.)

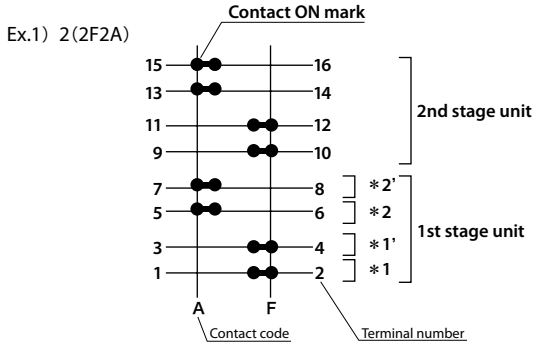

Contact *1 and *1', *2 and *2' are same position because each contact works with same mechanism.

OUTLINES

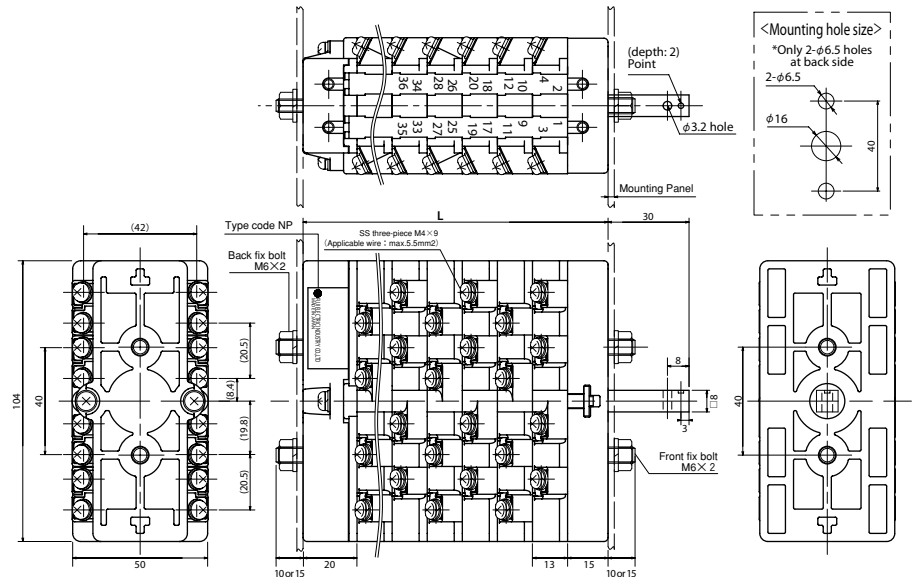

No. of Units	1	2	3	4	5	6	7	8	9	10	11	12	13	14	15
L(mm)	48	61	74	87	100	113	126	139	152	165	178	191	204	217	230



AUXILIARY SWITCH

GQ TYPE

TECHNICAL DATA

Contact ON (close) angle

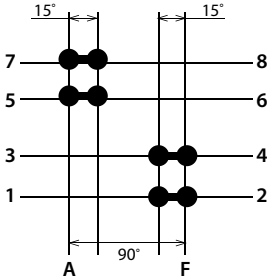

Standard ON angle is 15°, and other angles are also available.

*Contact ON angle may move left or right caused by gap of switch installment or link of a shaft. Please consider timing between the auxiliary switch and the device.

Close and break capacity

[Switching load under normal conditions]

Load class	Make			Break		
	Current (A)	Voltage (V)	Cos ϕ $T_{0.95}$ (ms)	Current (A)	Voltage (V)	Cos ϕ $T_{0.95}$ (ms)
AC-15	30	240	0.3	3	240	0.3
DC-13	0.55	250	300	0.55	250	300

Switching: 6,050 times

[Switching load under abnormal conditions]

Load class	Make			Break		
	Current (A)	Voltage (V)	Cos ϕ $T_{0.95}$ (ms)	Current (A)	Voltage (V)	Cos ϕ $T_{0.95}$ (ms)
AC-15	30	264	0.3	30	264	0.3
DC-13	0.605	275	300	0.605	275	300

Switching: 10 times

※AC-15, DC-13 follow IEC-60947-5-1 test condition.

Electrical life

Load class	Make			Break		
	Current (A)	Voltage (V)	Cos ϕ $T_{0.95}$ (ms)	Current (A)	Voltage (V)	Cos ϕ $T_{0.95}$ (ms)
AC-15	30	240	0.7	3	240	0.3
DC-13	0.55	250	300	0.55	250	300

Angular speed: 2π rad/s
 Switching: 50,000 times (AC-15)
 20,000 times (DC-13)
 Switching frequency: 360 times/h

* AC-15, DC-13 follow IEC-60947-5-1 test condition.

Rated operating voltage, current

Rated operating voltage (V)	AC		DC	
	Rated operating current		Rated operating current	
	Inductive load COS ϕ = 0.3 to 0.4	Resistance load	Inductive load L/R = 40ms	Resistance load
24	—	—	10	15
48	—	—	6	10
110	15	20	1.5	3
220	10	15	0.8	1.2

REFERENCE

Aim of Load Area (L/R=40ms. Life: 50,000 times operation)

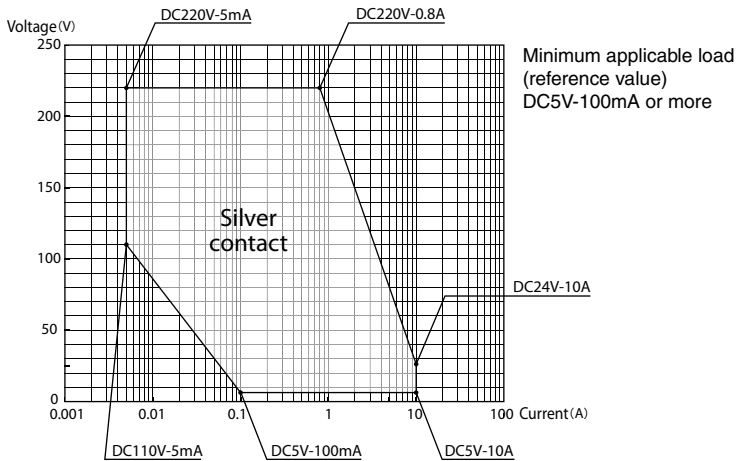

Unit inside structure (Contact "ON" status)

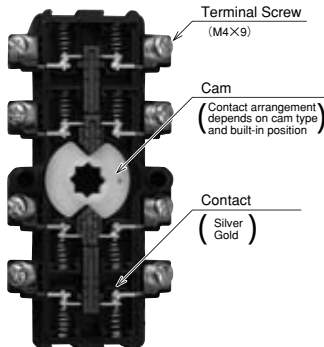

1 unit has 4 contacts.
(Each 2 contact at up and down side)



AUXILIARY SWITCH

GQ TYPE

Caution

Precautions for use

- Thoroughly check the operating conditions of the product with the specifications and outline drawing.
- Do not use the product in a condition exceeding the ratings, specifications and characteristic of the product. Failure to observe this instruction causes a fault of the product.
- To improve contact reliability, please use the product in a condition that does not exceed the ratings, even when the 2-pole or 3-pole contacts are used as a single pole.
- Do not to apply excessive pulling stress to the connection cable.
- Do not apply force in any direction other than the specified operating direction.
- The product performance has been evaluated at angular velocity of 2π rad/s. If the condition of angular velocity is different, verify actual performance of the product before use.
- With the operating link structure, care should be taken not to apply moment to the shaft rotation axis in any direction other than the specified rotating direction. Do not use the shaft rotation axis of this product as a rotation axis for driving other link. Failure to observe these instructions causes damage to the shaft and rotation axis.

Precautions for use, storage and transportation

- Avoid use and storage of the product in a place where the product may be exposed to ozone or corrosive gas. Otherwise, sulfide film or oxide film may deposit on the contact surface, causing unstable contact operation or contact failure.
- During storage and transportation of the product, avoid exposure to direct sunlight, and keep the product at normal temperature and normal humidity.
- If the ambient temperature rapidly changed in high-temperature/high-humidity environment, condensation may occur in the switch, which causes deterioration of insulation, break of coil, rusting, etc.
- Exercise caution about freezing when the ambient temperature becomes 0°C or lower. Freezing causes adhesion of moving parts and contact failure.
- This product is not waterproof, oil-proof and explosion-proof. Do not use this product in such an environment.
- Exercise caution about influence of external noise, surge, etc. on this product.

Precautions for mounting, removal and wiring

- If the product falls, product performance may deteriorate. In this case, do not use this product. To use this product, be sure to check appearance, specifications and performance of the product.
- Do not remove screws other than the terminal screw. Failure to observe this instruction cause a fault of the product.
- Recommended tightening torque for the terminal screw is 1.2 N·m.
- Before shipment of the product, the terminal screw is temporarily tightened. Securely tighten the screw before use, even if it is not used.
- If a mounting bolt is provided at the rear of the switch, be sure to fasten the switch at the front and rear securely.
- Recommended tightening torque for the mounting bolt (M6) at the rear of the switch is 2.5 N·m.
- Missed-connection may result in unintended operation, abnormal heating and fire.
- When mounting or removing the product, make sure that the product is not alive.
- For wiring of the product, be sure to use applicable cable and crimp terminal, in consideration of applied voltage and current.
- For a product which mounting pitch is fixed, be sure to observe the specified dimensions.

Precautions for inspection

- To clean the product, use vacuum, instead of air blow. Using air blow causes dust intrusion into the switch, resulting in contact failure.
- Do not disassemble the product during cleaning. Disassembling the product causes a fault of the product.
- If you find any damages to the product, replace it immediately.