

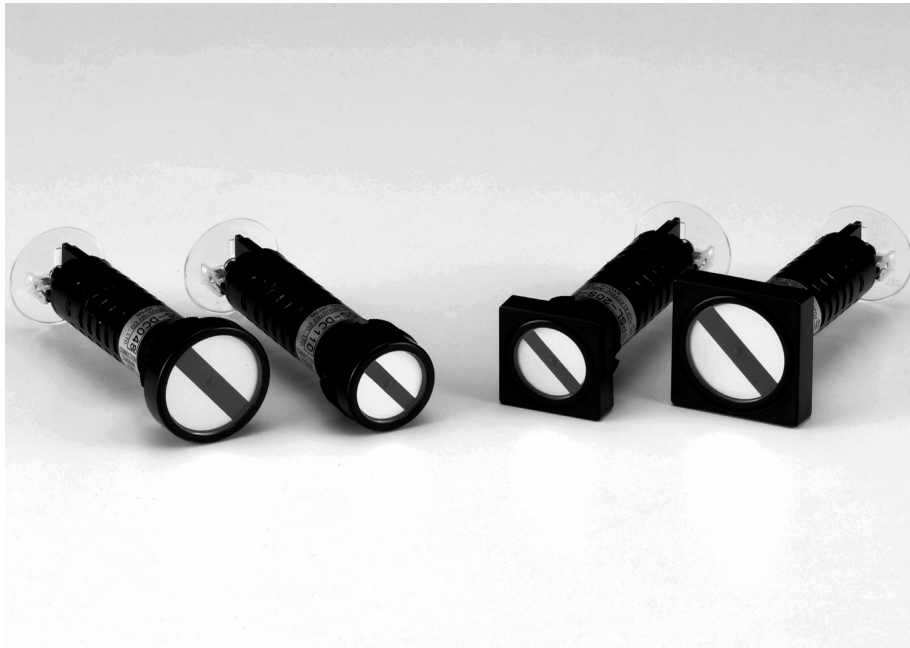

SEMAPHORE INDICATOR

SPSR TYPE, SPSL TYPE



SPECIFICATIONS (RATINGS, PERFORMANCE)

Specification	Type	SPSR/SPSL
Rated insulation voltage (Ui)		250V
Rated operational voltage		24V, 30V, 48V, 100 / 110V, 125V, 200 / 220V DC
Voltage fluctuation range		±15% (24V, 48V, 200 / 220V)
		-20 to 30% (100 / 110V, 125V)
Rated current		11mA
Insulation resistance		1,000MΩ or more (between live parts and mounting panel)
Power-frequency withstand voltage		2,000V AC / 1min.
Impulse withstand voltage		±4.5kV, 3 times for each pole (1.2 / 50μs)
Shock resistance		490m/s ² , in 6-axis directions, 3 times each
Service life		100,000 times or more
Degree of protection		IP52
Operating temperature		-20 to 60°C
Storing temperature		-30 to 75°C
Relative humidity		45 to 85%
Altitude		2,000 m max.
Applicable wire size		AWG 20 to 14
Screw size		M3.5 x 8, with square washer
Panel thickness		1 to 6mm
Weight		Approx. 30g

* For the overseas standard conformable ratings, refer to B48.

PILOT LAMP & INDICATOR

FEATURES

1

The SPS type indicators have acquired TÜV and CCC certification, and conform to the EN (IEC) standard.

Thus, these products have been certified as global standard products conformable with international standards. (TUV and CE marks are attached to the product body.)

2

With the compact design, the SPS type indicator meets the requirements for size and weight reduction.



3

With the energy-saving design, power consumption can be reduced to approx. one fourth that of conventional models.

* Rated operating current at 24 V DC:
(Conventional) SPR/L: approx. 37 mA
SPSR/L: approx. 9 mA

4

Twisted wires up to AWG14 size (equivalent to 2.5 mm²) can be connected.

5

To enhance safety, the terminal cover for wiring screw live parts is provided as a standard feature.

6

The round and square types can be selected as the face shape of the indicator. Indication can be differentiated by the face shape, which enhances the panel design easily.



7

Since the circuit status is indicated by the flag shape, erroneous recognition is prevented. The circuit ON/OFF status can be recognized at a glance.

(Conceptual image)

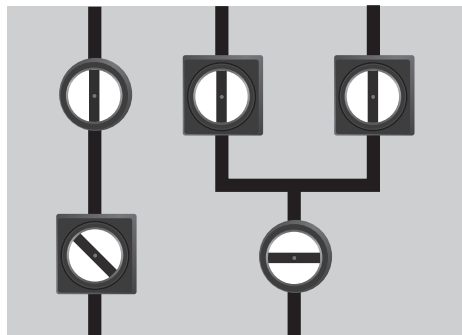



SEMAPHORE INDICATOR

SPSR TYPE, SPSL TYPE

HOW TO ORDER

[SPSR type, SPSL type]

SPS R - 2 0 S - DC110 - B B A

① ② ③ ④ ⑤ ⑥ ⑦ ⑧ ⑨

No.	Item	Code	Detail			Note
①	Basic type	SPS	—			SPS type
②	Face shape	R	Round			—
		L	Square			—
③	Face dimensions	2	φ 25mm □ 28mm		Flag width : 4mm	
		3	φ 32mm □ 35mm		Flag width : 6mm	
④	Flag shape		① Input	② Input	No input	—
		0	⊖	⊏	⊘	—
		1	⊏	⊘	⊖	—
		2	⊘	⊖	⊏	—
		3*1	⊖	⊏	⊘	TÜV and CE are not certified.
⑤	Terminal	S	Screw terminal			M3.5
⑥	Rated operational voltage	DC024	24V DC			—
		DC030	30V DC			—
		DC048	48V DC			—
		DC110	100 / 110V DC			—
		DC125	125V DC			—
		DC220	200 / 220V DC			—
⑦	Flag color	B	Black (N1.5)			—
⑧	Frame color	B	Black (N1.5)			—
⑨	Mounting hole size	No code	φ 20.5			Standard
		A*2	φ 22.3			Adapter mounting

*1 Surface dimension "2" is not selectable. Please be sure to select "3".

*2 A is special spec.

STANDARD PRODUCTS

SPSR-2 □ S

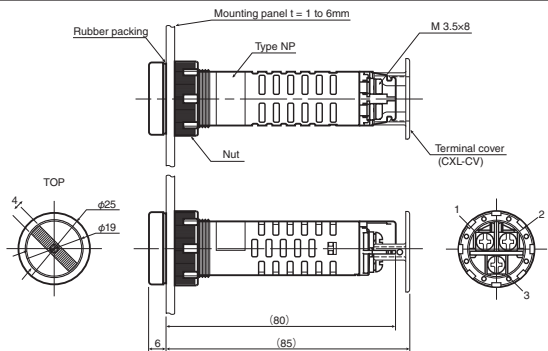

● Mounting hole

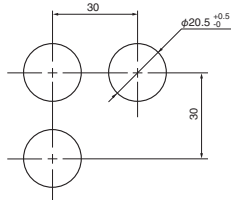

● Applicable accessories

Terminal cover	CXL-CV
Tightening tool	SPS-Q

PILOT LAMP & INDICATOR

A SWITCH

B PILOT LAMP & INDICATOR

C CONNECTING DEVICES

D ELECTRONIC DEVICES

SPSR-3 □ S

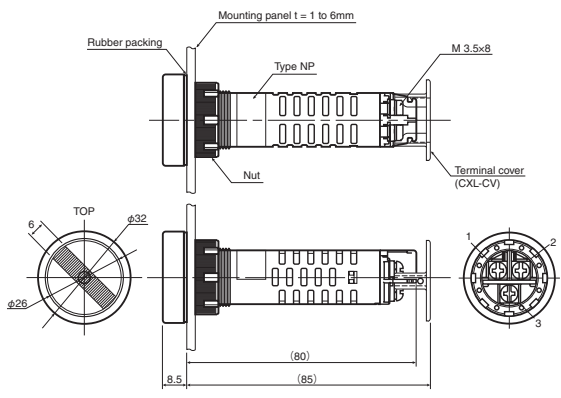

● Mounting hole

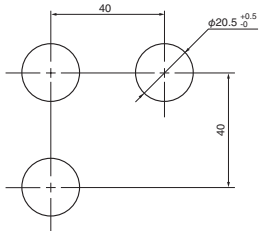

● Applicable accessories

Terminal cover	CXL-CV
Tightening tool	SPS-Q

SPSL-2 □ S

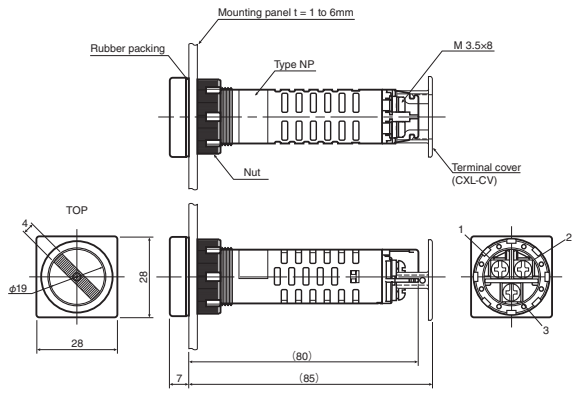

● Mounting hole

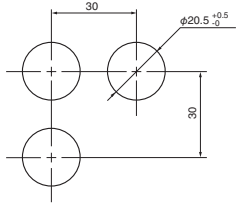

● Applicable accessories

Terminal cover	CXL-CV
Tightening tool	SPS-Q

PILOT LAMP & INDICATOR

OPERATION AND CIRCUIT SPECIFICATIONS

● Operation chart

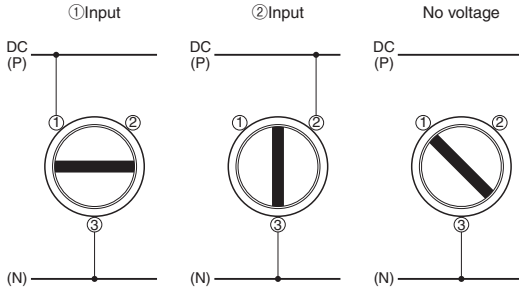

● Circuit diagram

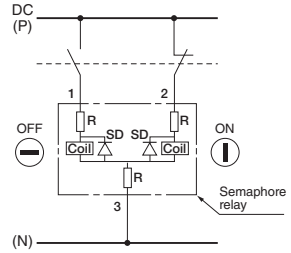

OVERSEAS STANDARD CONFORMABLE RATINGS (EN60947/IEC60947)

(1) Basic ratings and applications

No.	Item	Basic rating and application	IEC standard No.
1	Rated operational voltage	24V, 48V, 100 / 110V, 125V, 200 / 220V DC	IEC60947-5-1; 5.1-d
2	Rated operational current	11mA max.	IEC60947-5-1; 5.1-e
3	Rated insulation voltage (Ui)	250V	IEC60947-5-1; 5.1-f
4	IP code	IP 52	IEC60947-5-1; 5.1-l

(2) Normal operating conditions

No.	Item	Normal operating condition	IEC standard No.
1	Ambient temperature	-5°C to 40°C	IEC60947-1; 6.1.1
2	Altitude	2,000 m max.	IEC60947-1; 6.1.2
3	Atmospheric condition	Humidity: 90% max. (at 20°C), 50% (at 40°C) Microscopic environment: Pollution degree: 3	IEC60947-1; 6.1.3
4	Conditions during transport and storage	-25°C to 55°C +70°C for short periods (within 24 hours)	IEC60947-1; 6.2
5	Mounting of single hole mounted devices	φ20.5mm	IEC60947-5-1; 6.3.1
6	Range of panel thickness	1 to 6mm	IEC60947-5-1; 6.3.1.2
7	Minimum distances between center of mounting holes	SPSR/L-2□	30mm
		SPSR/L-3□	40mm

(3) Structure and performance

No.	Item	Structure and performance	IEC standard No.
1	Connecting capacity	Twisted wire: AWG20 (2 pieces max.)	IEC60947-1; 7.1.7
		Round crimp terminal: AWG14 to 20 (2 pieces max.)	IEC60947-1; AnnexD
2	Power-Frequency withstand voltage	Power-Frequency withstand voltage: 2,000V AC / 1min.	IEC60947-5-1; 7.2.3
3	Durability	Mechanical durability: 100,000 operations	IEC60947-5-1; AnnexC

Remarks: The SPS type indicators have acquired TÜV certification for the above items. For detailed information, contact Fuji Electric Industry.