



TEST TERMINALS

A-TYPE

STRUCTURES AND FEATURES

PLUG

Plug-in type eliminating hot-line work (ATP type)

The conventional jumper connection type has been changed to the plug-in type, which provides a safer structure eliminating dangerous hot-line work.

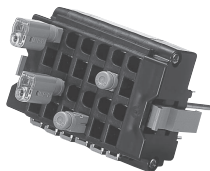

Short-circuit preventive structure against wiring mistakes (ATP type)

A short jack and a lead plug can be inserted to only each socket by selective stoppers.

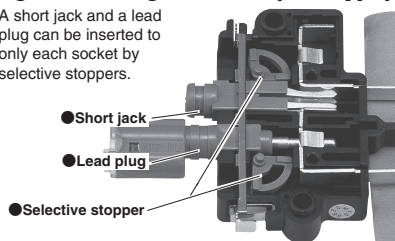

Locking structure to prevent disconnection

The locking structure prevents any disconnection between the lead plug, short jack, and terminal.

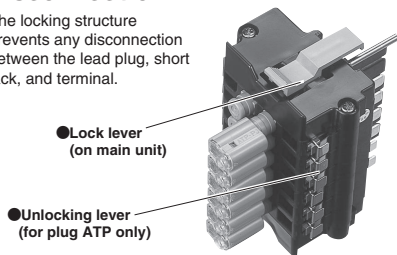

Guide pins for safe insertion

This safety structure prevents any wrong insertion by such as voltage-current type, number of poles, vertical mistakes.

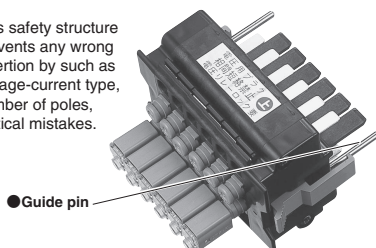

TERMINAL

Compact design with a completely new internal structure

The size of the panel rear has been down-sized to approximately a half of our former one by isolating the separable section from the jointed section.

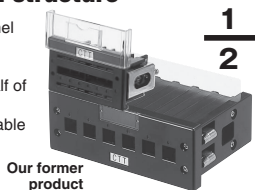

Our former product

Sliding protective cover free from misplacement

The protective cover, which was often misplaced, has been redesigned as a sliding type to enable work without removing it.

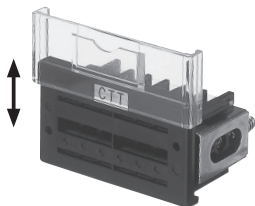

Highly reliable dual-contactor structure

The dual-contactor structure has been adopted for contact in the terminal. The triple-contactor structure has been used to provide more reliable contact between the terminal and the plug.

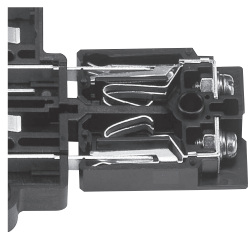

Easy identification by different colors of voltage and current type

The units for current are colored in black and those for current in gray to discriminate them. This allows you to carry out wiring while identifying the units for current and voltage.



For voltage (gray)



For current (black)

STANDARD PRODUCTS (TERMINAL)

ATT-A No. of poles (For current)

– Circuit opening prevention type –

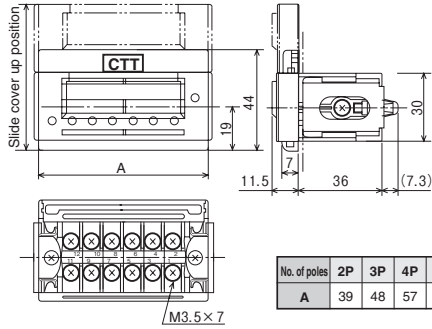
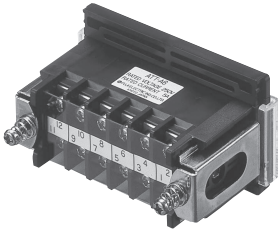

No. of poles	2P	3P	4P	6P	8P
A	39	48	57	75	93

● Standard equipment

ATP color NP

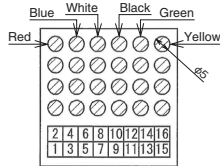

● Applicable plugs
ATP-A□, ATP-A□

● Min. mounting pitch

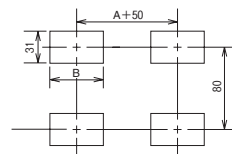

No. of poles	2P	3P	4P	6P	8P
B	35	44	53	71	89

ATT-V No. of poles (For voltage)

– Power-source contact prevention type –

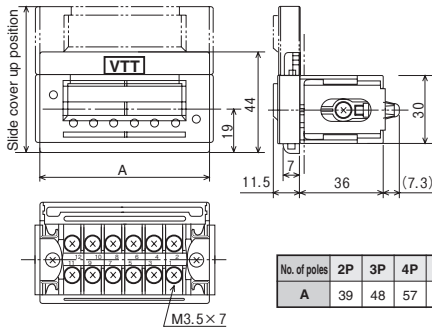
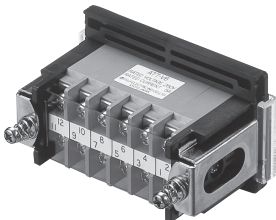

No. of poles	2P	3P	4P	6P	8P
A	39	48	57	75	93

● Standard equipment

ATP color NP

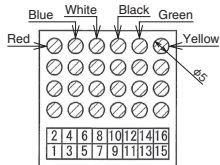

● Applicable plugs
ATP-V□, VL□, ATP-V□, VL□

● Min. mounting pitch

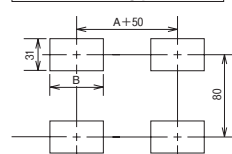

No. of poles	2P	3P	4P	6P	8P
B	35	44	53	71	89



TEST TERMINALS

A-TYPE

STANDARD PRODUCTS (PLUG)

ATP-A No. of poles (For current)

– Circuit opening prevention type –

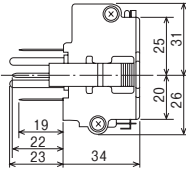
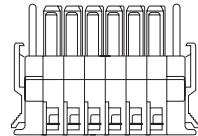
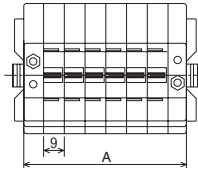
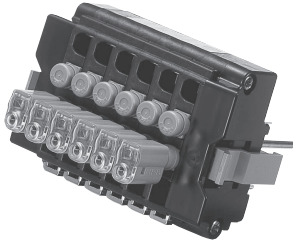

No. of poles	2P	3P	4P	6P	8P
A	35	44	53	71	89

● Applicable terminal
ATT-A □

● Standard equipment

ATP lead plug



ATP short jack



ATP color NP

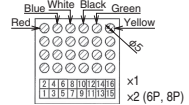

ATP-V No. of poles (For voltage)

– Power-source contact prevention type –

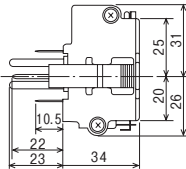
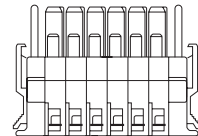
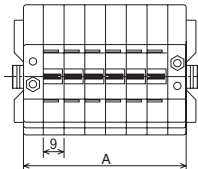
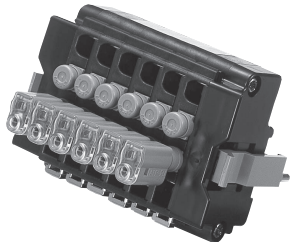

No. of poles	2P	3P	4P	6P	8P
A	35	44	53	71	89

● Applicable terminal
ATT-V □

● Standard equipment

ATP lead plug



ATP short jack



ATP color NP

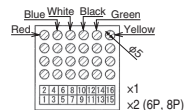

ATP-VL No. of poles (For voltage)

– Circuit opening prevention type –

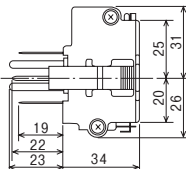
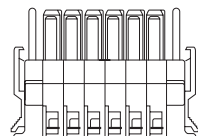
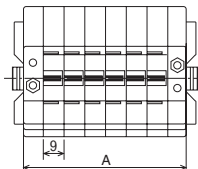

No. of poles	2P	3P	4P	6P	8P
A	35	44	53	71	89

● Applicable terminal
ATT-V □

● Standard equipment

ATP lead plug



ATP short jack



ATP color NP

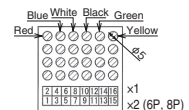

CONNECTING DEVICES

ATQ-A No. of poles (Screw type for current)

– Circuit opening prevention type –

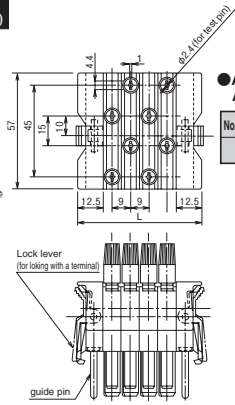
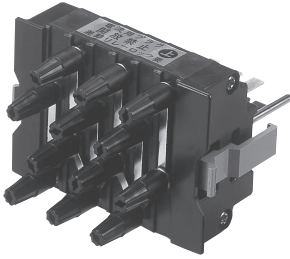

● Applicable terminal ATT-A □

No. of poles	2P	3P	4P	6P	8P
L	43	52	61	79	97

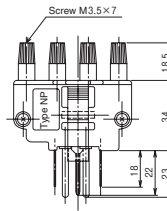

● Standard equipment

ATQ jumper A

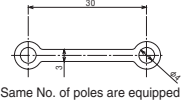

Same No. of poles are equipped

ATQ jumper B

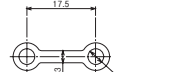

Same No. of poles are equipped

ATP color NP

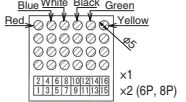

ATQ-V No. of poles (Screw type for voltage)

– Power-source contact prevention type –

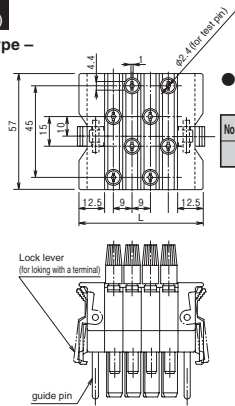
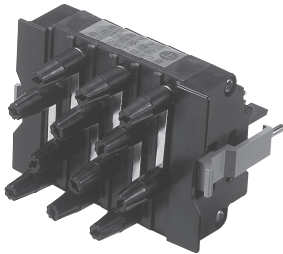

● Applicable terminal ATT-V □

No. of poles	2P	3P	4P	6P	8P
L	43	52	61	79	97

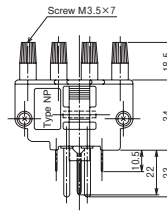

● Standard equipment

ATQ jumper A



Same No. of poles are equipped

ATQ jumper B

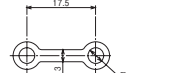

Same No. of poles are equipped

ATP color NP

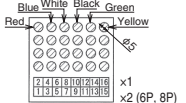

ATQ-VL No. of poles (Screw type for voltage)

– Circuit opening prevention type –

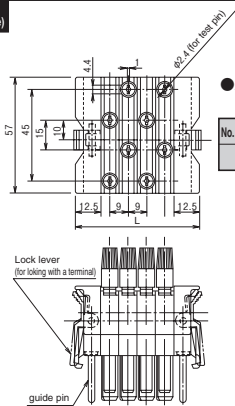
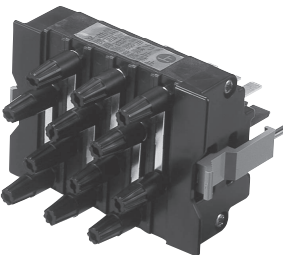

● Applicable terminal ATT-V □

No. of poles	2P	3P	4P	6P	8P
L	43	52	61	79	97

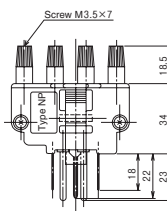

● Standard equipment

ATQ jumper A

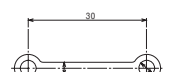

Same No. of poles are equipped

ATQ jumper B

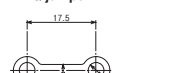

Same No. of poles are equipped

ATP color NP

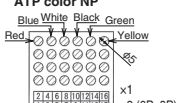



TEST TERMINALS

A-TYPE

ACCESSORIES

Box sets of ATPB plugs



Model	ATPB-A2-V2	ATPB-A3-V3	ATPB-A4-V4	ATPB-A6-V6	ATPB-A8	ATPB-V8	ATPB-A8-V8
Included items	ATP-A2 ATP-V2 4 lead plugs 4 short jacks 2 color NP (ATPB box)	ATP-A3 ATP-V3 6 lead plugs 6 short jacks 2 color NP (ATPB box)	ATP-A4 ATP-V4 8 lead plugs 8 short jacks 2 color NP (ATPB box)	ATP-A6 ATP-V6 12 lead plugs 12 short jacks 4 color NP (ATPB box)	ATP-A8 —— 8 lead plugs 8 short jacks 2 color NP (ATPB box)	ATP-V8 —— 8 lead plugs 8 short jacks 2 color NP (ATPB box)	ATP-A8 ATP-V8 16 lead plugs 16 short jacks 4 color NP (ATPB box)

Box sets of ATQB plugs

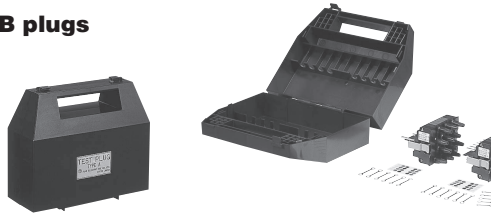

Model	ATQB-A2-V2	ATQB-A3-V3	ATQB-A4-V4	ATQB-A6-V6	ATQB-A8	ATQB-V8	ATQB-A8-V8
Included items	ATQ-A2 ATQ-V2 4 jumper A 4 jumper B 2 color NP (ATPB box)	ATQ-A3 ATQ-V3 6 jumper A 6 jumper B 2 color NP (ATPB box)	ATQ-A4 ATQ-V4 8 jumper A 8 jumper B 2 color NP (ATPB box)	ATQ-A6 ATQ-V6 12 jumper A 12 jumper B 4 color NP (ATPB box)	ATQ-A8 —— 8 jumper A 8 jumper B 2 color NP (ATPB box)	ATQ-V8 —— 8 jumper A 8 jumper B 2 color NP (ATPB box)	ATQ-A8 ATQ-V8 16 jumper A 16 jumper B 4 color NP (ATPB box)

ATP lead plug



ATP short jack



ATP color NP

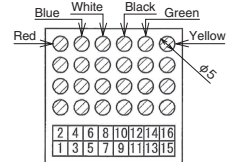

ATQ jumper A

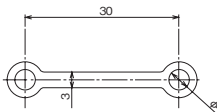

ATQ jumper B

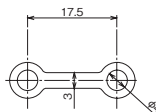

ATQ knob



■ Combinations of test terminals and plugs, and their descriptions

Test terminal	Test plug	Description
ATT-A□	ATP-A□ ATQ-A□	Combination of circuit opening prevention types
ATT-V□	ATP-V□ ATQ-V□	Combination of test power source contact prevention types
	ATP-VL□ ATQ-VL□	Combination of circuit opening prevention types (lap types)

CHARACTERISTIC OF EACH COMBINATION

■ Combination of ATT-A and ATP-A or ATQ-A (Circuit opening prevention)

The ATP-A plug has such a long plug terminal that the plug terminal closes before the contact of the ATT-A terminal opens when the plug is inserted. Therefore, the CT circuit never be opened when the plug is inserted or removed.

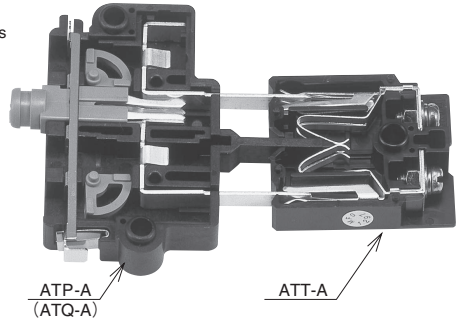

■ Combination of ATT-V and ATP-V or ATQ-V (Power-source contact prevention)

The ATP-V plug has a shorter plug terminal than the ATP-VL plug. Therefore, when the plug is inserted, the plug terminal closes after the contact of the ATT-V terminal has opened. Thus, even if another power source is inserted from the plug when the plug is inserted or removed, there will be no contact with the power source.

However, when the circuit voltage is measured using a test instrument, the relay malfunctions due to the momentary disconnection of the circuit and therefore requires itself to be blocked in advance.

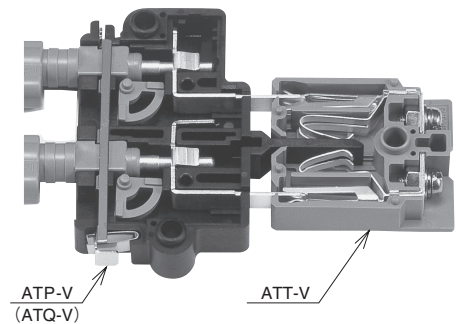

■ Combination of ATT-V and ATP-VL or ATQ-VL (Circuit opening prevention)

The ATP-VL plug has a long plug terminal as in the case with the ATP-A plug. Therefore, when the plug is inserted, the plug terminal closes before the contact of the ATT-V terminal opens. For this reason, the circuit never be opened when the plug is inserted or removed. When the circuit voltage is measured using a test instrument, the relay does not malfunction due to the momentary disconnection of the circuit. However, if you try to insert another power source from the plug, contact with the power source will occur temporarily. Before inserting the external power source, therefore, be sure to turn it OFF.

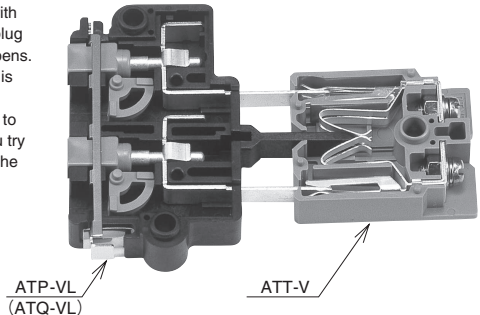



A-TYPE

OPERATING INSTRUCTIONS

■ Mounting onto panel (ATT)

- 1) Remove two fittings from the terminal.
- 2) Insert the terminal into the mounting hole from the panel front, and lock it with the fittings.

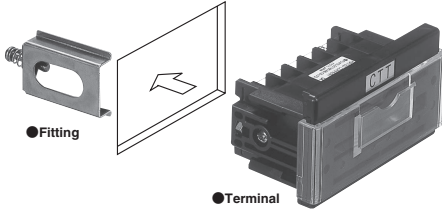

■ Connecting lead wire to lead plug (ATP)

- 1) Insert a transparent cap into the leading end of the lead wire of 2 mm² (to be purchased separately).
- 2) Strip off the leading end of the lead wire and then clamp the supplied L-shaped solderless terminal on it.
- 3) Retain the clamped lead wire to the plug jack using the supplied M3 screw.
- 4) Fit the transparent cap to the plug jack.

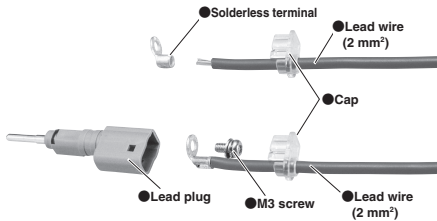

■ Mounting and removing short jack and lead plug

- 1) Mount the short jack and lead plug in place while holding down the unlocking lever with your finger. After mounting them, check that they will not fall off or otherwise loosen.

* For connecting a circuit, refer to the typical procedures for connections and the typical procedure for use.

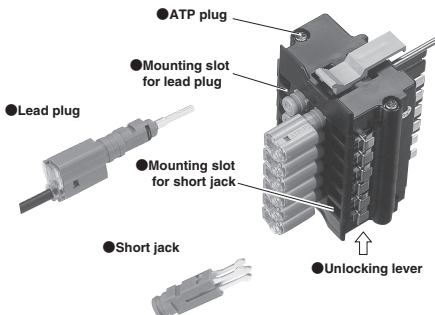

■ Typical procedure for use (ATP)

To measure current or voltage, use the test plug (ATP) for the test terminal (ATT).

- 1) Slide the front transparent cover on the test terminal upward until it clicks, so that it is locked.
- 2) Insert the short jack and lead plug into the slots indicated in the following figures. (In this case, before inserting them, be sure to press the unlocking lever that can be found below the test plug.)

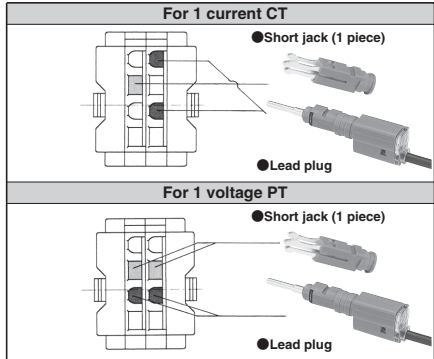

- 3) Connect a measurement instrument using the lead wire connected to the lead plug.
- 4) After the connection has been completed, insert the test plug into the test terminal and then start the test. For the connections including those for the test terminal, see the following diagrams:

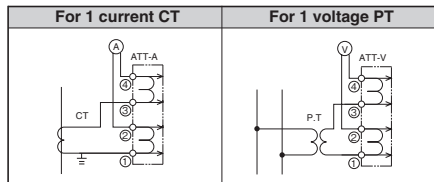

⚠ Precautions on use

- A connection mistake can result in an accident. Before the test, carefully check the connections.
- Before use, be sure to check that the lead wires are free from any anomaly such as electrical discontinuity.
- Do not pull the protective cover toward the front.
- To insert or remove the test terminal or plug, carefully do it in parallel with the test terminal.
- After inserting the plug, take care not to give force to the lead wire.
- Do not open CT circuits for safety.
- Be sure to close the protective cover in normal cases other than a test using the test plug.
- Purchase usage ID seals separately.
- To store the connection plug, take care that its contactors are not bent or otherwise deformed.
- The test plug is available in two types, V (power-source contact prevention type) and VL (circuit disconnection prevention type), which should be chosen according to your applications.

TYPICAL PROCEDURES FOR CONNECTIONS (USING ATT AND ATP)

●Connections for measuring voltage and current
(be sure to lock relays)

●Connections for calibrating voltmeter and
ammeter (turn OFF the power switch at insertion)

